



TERMALINE[®] LOAD RESISTOR
SERIES 8745/8746

OPERATION MANUAL

© COPYRIGHT 2021 BY BIRD TECHNOLOGIES, INC.
INSTRUCTION BOOK PART NUMBER 920-8745/46 REV. F

TERMALINE[®] IS A REGISTERED TRADEMARK
OF BIRD ELECTRONIC CORPORATION

Safety Precautions

The following are general safety precautions that are not necessarily related to any specific part or procedure, and do not necessarily appear elsewhere in this publication. These precautions must be thoroughly understood and apply to all phases of operation and maintenance.

WARNING

Keep Away From Live Circuits

Operating Personnel must at all times observe general safety precautions. Do not replace components or make adjustments to the inside of the test equipment with the high voltage supply turned on. To avoid casualties, always remove power.

WARNING

Shock Hazard

Do not attempt to remove the RF transmission line while RF power is present.

WARNING

Do Not Service Or Adjust Alone

Under no circumstances should any person reach into an enclosure for the purpose of service or adjustment of equipment except in the presence of someone who is capable of rendering aid.

WARNING

Safety Earth Ground

An uninterruptible earth safety ground must be supplied from the main power source to test instruments. Grounding one conductor of a two conductor power cable is not sufficient protection. Serious injury or death can occur if this grounding is not properly supplied.

WARNING

Resuscitation

Personnel working with or near high voltages should be familiar with modern methods of resuscitation.

WARNING

Remove Power

Observe general safety precautions. Do not open the instrument with the power on.

Safety Symbols

WARNING
Warning notes call attention to a procedure, which if not correctly performed, could result in personal injury.

CAUTION
Caution notes call attention to a procedure, which if not correctly performed, could result in damage to the instrument.

Note: *Calls attention to supplemental information.*



The caution symbol appears on the equipment indicating there is important information in the instruction manual regarding that particular area.



This symbol indicates that the unit radiates heat and should not be touched while hot.

Warning Statements

The following safety warnings appear in the text where there is danger to operating and maintenance personnel, and are repeated here for emphasis.

WARNING
Never attempt to disconnect RF equipment from the transmission line while RF power is being applied. Leaking RF energy is a potential health hazard.

See page 8 and 10.

WARNING
Never attempt to connect or disconnect RF equipment from the transmission line while RF power is being applied. Leaking RF energy is a potential health hazard.

See page 11.

WARNING
The resistor used in this load consists of a resistive film on a special substrate. If the substrate is broken, there will probably be sharp pieces or splinters inside the load housing. Caution should be exercised to avoid possible injury.

See page 15.

Caution Statements

The following equipment cautions appear in the text and are repeated here for emphasis.

<p>CAUTION</p> <p>The water flow must be kept in the proper direction; incorrect flow will cause almost immediate burnout.</p>

See page 6.

<p>CAUTION</p> <p>Do not apply more than rated RF power to the load. The water flow rate and inlet temp. (5° C to 60° C) must be as specified:</p>			
<p>Models (8745/8746)</p>	<p>Power 20 kW</p>	<p>5° C 6 gpm (22.7 lpm)</p>	<p>60° C 8 gpm (30 lpm)</p>
<p>Adequate and uninterrupted full water flow is more critical than temperature.</p>			

See page 8.

<p>CAUTION</p> <p>Verify cooling liquid is flowing through the load before RF power is applied and ensure the cooling liquid supply is not interrupted while load is in operation. Even momentary interruption of coolant supply while RF power is applied will cause almost immediate burnout.</p>
--

See page 8.

<p>CAUTION</p> <p>Never reverse the cooling water connections. It is very important for the safety of the load resistor to observe proper flow direction. Also, when the load is first installed or is reconnected, run the water for approximately one minute to fill the system and remove all air pockets before applying RF power.</p>

See page 8.

Safety Statements

USAGE

ANY USE OF THIS INSTRUMENT IN A MANNER NOT SPECIFIED BY THE MANUFACTURER MAY IMPAIR THE INSTRUMENT'S SAFETY PROTECTION.

USO

EL USO DE ESTE INSTRUMENTO DE MANERA NO ESPECIFICADA POR EL FABRICANTE, PUEDE ANULAR LA PROTECCIÓN DE SEGURIDAD DEL INSTRUMENTO.

BENUTZUNG

WIRD DAS GERÄT AUF ANDERE WEISE VERWENDET ALS VOM HERSTELLER BESCHRIEBEN, KANN DIE GERÄTESICHERHEIT BEEINTRÄCHTIGT WERDEN.

UTILISATION

TOUTE UTILISATION DE CET INSTRUMENT QUI N'EST PAS EXPLICITEMENT PRÉVUE PAR LE FABRICANT PEUT ENDOMMAGER LE DISPOSITIF DE PROTECTION DE L'INSTRUMENT.

IMPIEGO

QUALORA QUESTO STRUMENTO VENISSE UTILIZZATO IN MODO DIVERSO DA COME SPECIFICATO DAL PRODUTTORE LA PROIZIONE DI SICUREZZA POTREBBE VENIRNE COMPROMESSA.

SERVICE

SERVICING INSTRUCTIONS ARE FOR USE BY SERVICE - TRAINED PERSONNEL ONLY. TO AVOID DANGEROUS ELECTRIC SHOCK, DO NOT PERFORM ANY SERVICING UNLESS QUALIFIED TO DO SO.

SERVICIO

LAS INSTRUCCIONES DE SERVICIO SON PARA USO EXCLUSIVO DEL PERSONAL DE SERVICIO CAPACITADO. PARA EVITAR EL PELIGRO DE DESCARGAS ELÉCTRICAS, NO REALICE NINGÚN SERVICIO A MENOS QUE ESTÉ CAPACITADO PARA HACERLO.

WARTUNG

ANWEISUNGEN FÜR DIE WARTUNG DES GERÄTES GELTEN NUR FÜR GESCHULTES FACHPERSONAL.

ZUR VERMEIDUNG GEFÄHRLICHE, ELEKTRISCHE SCHOCKS, SIND WARTUNGSARBEITEN AUSSCHLIEßLICH VON QUALIFIZIERTEM SERVICEPERSONAL DURCHZUFÜHREN.

ENTRETIEN

L'EMPLOI DES INSTRUCTIONS D'ENTRETIEN DOIT ÊTRE RÉSERVÉ AU PERSONNEL FORMÉ AUX OPÉRATIONS D'ENTRETIEN. POUR PRÉVENIR UN CHOC ÉLECTRIQUE DANGEREUX, NE PAS EFFECTUER D'ENTRETIEN SI L'ON N'A PAS ÉTÉ QUALIFIÉ POUR CE FAIRE.

ASSISTENZA TECNICA

LE ISTRUZIONI RELATIVE ALL'ASSISTENZA SONO PREVISTE ESCLUSIVAMENTE PER IL PERSONALE OPPORTUNAMENTE ADDESTRATO. PER EVITARE PERICOLOSE SCOSSE ELETTRICHE NON EFFETTUARRE ALCUNA RIPARAZIONE A MENO CHE QUALIFICATI A FARLA.

CONNECT INTERLOCK TO TRANSMITTER BEFORE OPERATING.

BRANCHER LE VERROUILLAGE À L'ÉMETTEUR AVANT EMPLOI.

CONECTE EL INTERBLOQUEO AL TRANSMISOR ANTES DE LA OPERACION.

VOR INBETRIEBNAHME VERRIEGELUNG AM SENDER ANSCHLIESSEN.

PRIMA DI METTERE IN FUNZIONE L'APPARECCHIO, COLLEGARE IL DISPOSITIVO DI BLOCCO AL TRASMETTITORE.

About This Manual

This manual covers the operating and maintenance instructions for the following models

8745 8746

Changes to this Manual

We have made every effort to ensure this manual is accurate. If you discover any errors, or if you have suggestions for improving this manual, please send your comments to our Solon, Ohio factory. This manual may be periodically updated. When inquiring about updates to this manual refer to the part number and revision on the title page.

Literature Contents

Introduction — Describes the features of the load resistor, lists equipment supplied and optional equipment, and provides power-up instructions.

Theory of Operation — Describes how the load resistor works.

Installation — Describes the power supply and load connection instructions.

Operating Instructions — Describes the base level operation instructions.

Maintenance — Lists routine maintenance tasks as well as troubleshooting for common problems. Specifications and parts information are also included.

TABLE OF CONTENTS

Safety Precautions	i
Safety Symbols	ii
Warning Statements	ii
Caution Statements	iii
Safety Statements	iv
About This Manual	vii
Changes to this Manual	vii
Literature Contents	vii
Chapter 1 Introduction	1
Purpose and Function	1
Description	1
Optional Equipment	1
Direct Power Measurement	1
Chapter 2 Theory of Operation	2
General	2
Heat Transfer	2
Cooling Water	3
Water Quality	3
Closed System Water Mixtures	3
Flow Interlock Control Circuit (Optional)	4
Chapter 3 Installation	5
General	5
Load Resistor Connection	5
Water Line Attachment	6
Cooling Water Quality	6
Flow Switch (Optional Item)	6
Control Box (Optional Item)	7
Preoperational Checkout	7
Chapter 4 Operating Instructions	8
General	8
Normal Operation	8
Power On Procedure	8
Shutdown Procedure	9
Operating as an RF Wattmeter	9

Chapter 5 Maintenance	10
General	10
Preventative Maintenance	10
Inspection	10
Cleaning	10
Outside Surface	10
RF Connector Surfaces	10
Optional Flow Switch	10
RF Assembly Resistance Test	11
DC Resistance Measurement	11
Troubleshooting	12
Repair	12
Replacing a Resistive Element	12
Inspecting the Unit	13
Installing the Resistor	15
Replacing Fractured Resistors	15
Installing a Replacement Resistor	17
Optional Equipment Repair	17
Replace the Water Flow Switch	17
Replace Time Delay Relay	17
Replace the Lamp	18
Additional Repairs	18
Storage	19
Shipping	19
Customer Service	19
Specifications	20
Replacement Parts	21
RF Connector Parts Assigned Per Model Type:	21
Model 8745 - 3-1/8" EIA Connector 50 ohms	21
Model 8746 - 3-1/8" Unflanged Connector Flush Center Conductor 50 ohms	21
For Both Models	21
Optional Equipment	22
Accessory Coupling Kits	22
Limited Warranty	24

Purpose and Function

The Model 8745/46 Termline Load Resistor is designed as a compact, low-reflection, and non-radiating termination for RF transmission lines. Cooled by internal water flow, it generates almost no surface heat, making installation space minimal and convenient. The load can safely dissipate up to 20 kilowatts of continuous power when used in a 50 ohm coaxial transmission line system.

Each model uses a 3-1/8 inch connector, [see "Specifications" on page 20](#) for individual models. They will maintain a VSWR of less than 1.1 to 1.0 from 1000 Hz up to 900 MHz. These loads are intended for use on CW, AM, FM, SSB, and TV modulation envelopes, and within certain limitations on radar or pulse modes. Information on applications involving pulse-type signals should be obtained directly from Bird Electronic Corporation.

Description

The Model 8745 and 8746 equipment consists of the Load Resistor unit. They have a field replaceable resistive element. The replacement procedure is included in ["Maintenance" on page 10](#).

Optional Equipment

An accessory protective Control System is available as optional equipment. When properly installed, this system protects the load by shutting off the RF power when water flow is too low or interrupted. Discussions of the flow control pertaining to ["Installation" on page 5](#) and ["Maintenance" on page 10](#) should be ignored when not applicable.

Direct Power Measurement

When used in conjunction with a Bird Model 6810 Series Thru-line Wattmeter or 3127 Series Panel Meters, these RF load resistors may be used for direct reading power measurements up to 20 kilowatts.

General

The Termaline Coaxial Load Resistor utilizes an external water supply for the direct cooling of the resistor element. By using this technique, the need for an intermediate dielectric fluid to transfer the heat generated in the resistor element has been eliminated, reducing the physical size of the load to a virtual minimum. This simplified system allows the use of the loads in more varied environments, and attachment in any orientation.

Heat Transfer

The 50 ohm resistor consists of a high temperature substrate tube with a deposited resistive film. The heat generated by absorption of RF power is transferred from the heated film to the water flowing over it, through a restricted chamber surrounding the resistor body. This water, first diverted to the front of the load resistor by a special inside tube, passes over the entire length of the resistor and is discharged through the sealed water chamber at the rear. The dielectric characteristics and distinctive design of these enclosures provide a very accurate 50 ohm termination over the specified frequency range of this load (1000 Hz to 900 MHz).

The absence of intermediate cooling fluids considerably simplifies the construction and sealing of this unit. It can be readily disassembled in the field for resistor element replacement ([see "Maintenance" on page 10](#)).

Because there is practically no heat transfer to the outer housing of the load, the housing remains at a cool ambient temperature even under full power conditions. Virtually all of the power input to the load is transformed into heat which is carried away by the cooling water. Therefore, the differential in output and input temperatures of the water multiplied by the amount of flow constitutes a very accurate measurement of the power consumed by the load. The amount of power dissipation may be calculated using the following formula:

For Celsius Temperatures:	$P = 0.263(T_1 - T_2)GPM$
For Fahrenheit Temperatures:	$P = 0.146(T_1 - T_2)GPM$
Where:	<p>P = Power in Kilowatts T_1 = Outlet Water Temperature T_2 = Inlet Water Temperature GPM = Water Flow in Gallons Per Minute</p>

Cooling Water

Use only potable water or potable water mixed with pure technical grade ethylene glycol in these loads. See [Water Quality](#) below for acceptable forms of water. See [Closed System Water Mixtures](#) for the acceptable water mixture for use in a closed system.

Water Quality

CAUTION

Do not use Automotive anti-freeze, stop-leak solutions, sealants, or corrosion inhibitors used in coolant solutions for these loads. Use of these additives can negatively impact load performance and may cause premature failure.
Use of unapproved coolants will void the warranty.

The following types of water are considered safe for the cooling of the 8745/46 Loads: purified, filtered city, or soft water. In general, any potable water is suitable for cooling the load.

These RF loads are affected by impurities or chemical additives in the cooling water. The effects can include high VSWR, overheating, and/or leaks.

Sea water or silty water should not be used for cooling the loads. The presence of salts in the water will make the device unusable because the salt will cause a rapid increase in VSWR.

Impurities, particularly those impurities that accumulate in the form of scale on the exposed surfaces of the fluid paths of the load assembly. These deposits may result in an increase in the thermal and/or fluid resistance(s) of the load and may in turn cause the load to overheat and fail.

Closed System Water Mixtures

WARNING

Ethylene glycol is toxic. Do not take internally.
Avoid contact with eyes, skin, and clothing. Avoid breathing vapor. Wash thoroughly after handling.

CAUTION

Use only potable water or potable water mixed with pure technical grade ethylene glycol. Use of any other coolant, including those containing additives or dyes, stop leak solutions, sealants, or corrosion inhibitors will void the warranty.
Use of unapproved coolants will negatively impact load performance and may cause premature failure.

Water is the primary coolant for the Bird 8745/46, however, a mixture of potable / distilled water and pure technical grade ethylene glycol is acceptable in closed systems. Ethylene glycol should be added to prevent bacterial growth and freezing; 10% to 35% ethylene glycol is recommended. Using at least 10% will prevent bacterial growth and at least 35% will protect against freezing to – 20°C.

Flow Interlock Control Circuit (Optional)

The interlock control circuit provides instantaneous fail-safe protection of the transmitter and load in the event of even a momentary interruption of the cooling water supply. This protection is necessary because dissipation of the heat generated by the RF power absorption is critically dependent upon a required minimum water flow rate regardless of inlet water temperature.

The water flow switch, attached to the water inlet of the load, is factory calibrated to open the electrical contacts whenever the water flow drops below six gallons per minute and close when the water flow exceeds this value.

When the water flow switch contacts open, the time delay relay switch is deactivated, which in turn, opens the interlock switch causing immediate shutdown of the transmitter or other signal source. The time delay relay also keeps the interlock switch "Open" for a 12 ± 2 second interval after the minimum flow of six gallons per minute has been reestablished. This safeguarding feature assures proper operation of the cooling system before RF power can be applied to the load, preventing damage or burnout of the resistor element.

The control assembly also includes a large light on top of the box. This red light should be freely visible from nearly all front angles in the operating vicinity of the load unit/control assembly. After proper installation, ([see "Installation" on page 5](#)) when the light is lit the RF load is ready to receive power, or when not lit indicates trouble in the cooling supply (control).

General

The compact design of the Termaline Load Resistor enables it to be installed in very small spaces. It requires no ventilation and may be placed in any orientation. Do not install where it will be subjected to severe vibration or physical shock.

The load is ready for connection as received from the factory. It is useful to first check the 50 ohm input resistance of the load and record this data before attachment, [see "Maintenance" on page 10](#).

Load Resistor Connection

Note: *Use a dry cleaning solvent that does not leave a residue.*

1. Clean all conductor and insulator surfaces on the transmission line face and the RF input connector.

Note: *Do not tighten the bolt and nut sets.*

2. Attach the load resistor to the RF line but do not tighten.
3. Use connector kits for respective models as follows:
 - Model 8745, 3-1/8 inch EIA, swivel flange, 50 ohms
 - a. Use 3-1/8 inch EIA coupling kit, P/N 4600-020, which includes: six each 3/8-16 x 1-1/2 inch bolt and nut sets, O-Ring, and insulated center bullet.
 - b. Insert the center bullet.
 - c. Push it in to seat the insulator in the facing.
 - d. Install O-Ring in groove if required.
 - e. Connect the coaxial input in a straight line, push carefully on the center contact to close.

Note: *The swivel flange on the load makes connection independent of a fixed flange on the coaxial input.*

- f. Insert bolt sets and tighten the nuts evenly all around.
- Model 8746, 3-1/8 inch unflanged, 50 ohms, flush center conductor:
 - a. Use coupling kit, P/N 5-726 or RCA MI-27791K-4A, which includes: outer sleeve with two clamping bands and the center conductor coupling bullet.
 - b. Insert the center bullet.
 - c. Bottom the center bullet on the midpoint nibs.
 - d. Position the outer sleeve, with clamping bands over input connector.
 - e. Introduce the transmission line and seat it snugly against the coupling stops.
 - f. Position the clamp bands evenly about 1-3/4 inches apart and tighten.
4. Rotate the load so that the warning label shows and the outlet water tube is in a convenient position.
 5. Secure the clamps or bolt set firmly and evenly around the RF connection.

Note: *Do not disturb the socket head cap screws that join the connector section to the main housing.*

6. Install water inlet and outlet connections. See ["Water Line Attachment" on page 6](#).

Water Line Attachment

CAUTION

The water flow must be kept in the proper direction; incorrect flow will cause almost immediate burnout.

The RF Load comes supplied with standard 3/4 inch hose fittings for attaching the water supply and drain lines. The water INLET, at the back on center, and water OUTLET, adjacent at 90° to the inlet, mate with 3/4 inch water hose connectors.

If the unit is factory equipped with the optional control system, the water flow switch is installed on the water inlet line.

For field installation of the optional control system [see "Flow Switch \(Optional Item\)" on page 6.](#)

For rigid piping connections, replace both the water inlet and outlet hose adapters, Bird P/N 5-065-2, with 1/2 inch male pipe or pipe fittings.

Cooling Water Quality

CAUTION

Use only potable water or potable water mixed with pure technical grade ethylene glycol. Use of any other coolant, including those containing additives or dyes, stop leak solutions, sealants, or corrosion inhibitors will void the warranty.
Use of unapproved coolants will negatively impact load performance and may cause premature failure.

CAUTION

Do not use Automotive anti-freeze, stop-leak solutions, sealants, or corrosion inhibitors used in coolant solutions for these loads. Use of these additives can negatively impact load performance and may cause premature failure.
Use of unapproved coolants will void the warranty.

Water quality is important. See "[Cooling Water](#)" on page 3 for an explanation and description. In general, any potable water is satisfactory. This would include purified, filtered, city supply, or soft water.

Flow Switch (Optional Item)

The ports of the flow switch are 3/4 inch NPT Female. The direction of flow is marked on the casting of the flow tube and on the operating head. Observe carefully, incorrect connection will restrict the water flow and cause load failure. The flow switch may be connected to the inlet or the outlet side of the load, preferably as close to the load as possible. Be certain the water flow through the switch is in the correct direction. Connect with a 1/2 inch NPT nipple and a 1/2 to 3/4 inch bushing, Bird P/N 5-489-1 and 5-490-1, or connect by hose or pipes. In either case, the flow switch should not be over 20 feet from the load. Alternatively, attach the hose to the switch with a 3/4 inch hose nipple, Bird P/N 5-903.

- Do not connect flow switch electrical leads at this time
- Turn on the water and check the system

Control Box (Optional Item)

The wiring center and remaining elements of the control system are contained in the control box. This includes a terminal strip and three BX cable clamps for the input connections, a lamp, and a delay timer. Only wiring material is needed for connecting the flow switch to the control box. The control unit operates on 115 VAC, P/N 8750-101-1.

The lamp on top of the box is a safe operation indicator; it lights only when AC power is on and an adequate water supply is flowing. After the lamp lights up, a 12 ±2 second time delay allows sufficient time for the water flow to stabilize before closing the transmitter interlock.

The control box is mounted by means of four 1/4 inch holes on a 5 x 5 inch (127 x 127 mm) square on the back. Locate the box for the best view of the lamp and for easy attachment of the BX cable clamps and wiring.

Connect the control leads as follows:

- Water Flow switch leads to terminals 3 and 5.
- Interlock Switch leads to terminals 6 and 7.
- AC power source to terminals 2 and 3.

Preoperational Checkout

Note: Before attempting to operate the RF load, whether under test or actual operating conditions, TEST the complete water system and INTERLOCK CONTROL as follows:

1. Ensure the AC and transmitter interlock power are OFF.
2. Connect an ohmmeter across terminals six and seven (interlock).
3. Turn on AC power.
4. Turn on water supply.
5. Note when the water flow switch operates (audible click).

Note: In not less than 10 seconds (12 ±2) the ohmmeter should signify a closed condition across terminals six and seven, indicating operation of the time delay switch.

6. Ensure water flow from the OUTLET connection of load is at least 6 gpm (22.7 lpm) at 5° C (41° F) through 8 gpm (30 lpm) at 60° C (140° F).

Note: As a precautionary measure, the Preoperational Checkout should be performed each time the load is put into service.

General

The Termaline RF Load is not equipped with any operating controls, therefore, operators don't need to be present when in use. Proper operation of the equipment is assured if the instructions contained in ["Installation" on page 5](#) are followed exactly.

Do not apply more than the rated RF power to the load. The water flow rates 6 - 8 gpm (22.7 - 30 lpm) and inlet water temperature, 5° C to 60° C (41° F to 140° F), must be maintained. In reality, an adequate and uninterrupted water flow is more critical than the actual water temperature.

Normal Operation

WARNING

Never attempt to disconnect RF equipment from the transmission line while RF power is being applied. Leaking RF energy is a potential health hazard.

CAUTION

Do not apply more than rated RF power to the load. The water flow rate and inlet temp. (5° C to 60° C) must be as specified:

Models (8745/8746)	Power 20 kW	5° C 6 gpm (22.7 lpm)	60° C 8 gpm (30 lpm)
Adequate and uninterrupted full water flow is more critical than temperature.			

CAUTION

Verify cooling liquid is flowing through the load before RF power is applied and ensure the cooling liquid supply is not interrupted while load is in operation. Even momentary interruption of coolant supply while RF power is applied will cause almost immediate burnout.

CAUTION

Never reverse the cooling water connections. It is very important for the safety of the load resistor to observe proper flow direction. Also, when the load is first installed or is reconnected, run the water for approximately one minute to fill the system and remove all air pockets before applying RF power.

Power On Procedure

1. Turn on the AC power (if the load is equipped with an interlock system).
2. Turn on the water supply (verify water flow rate is sufficient).
3. Check for proper interlock operation (if the load is equipped with an interlock system).
4. Check that all coaxial power line connections are properly tightened.
5. Apply RF power to the load.
6. Proceed according to instructions pertaining to the specific transmitting equipment.

Shutdown Procedure

1. Turn off the RF power to the load.
2. Wait at least one minute to allow the resistor substrate time to cool.
3. Turn off the AC power (if the load is equipped with an interlock system).
4. Turn off the water supply.

Note: *Always do this last.*

Operating as an RF Wattmeter

The RF load can be combined with a Bird Rigid Line Series Thruline Wattmeter to form an absorption-type wattmeter by inserting the wattmeter line section just ahead of the RF load. Installation and operation of the wattmeter is covered in the Thruline Wattmeter operation manual.

Note: *Select a wattmeter type appropriate to the input connector of the load resistor, consult the Bird catalog or contact the Company.*

1. Install wattmeter in the line section at the input of the RF Load.
2. Proceed with operating functions in "[Normal Operation](#)" on page 8.
3. Rotate the element in the Thruline Wattmeter's socket to monitor incident or reflected power.

Note: Measurements are taken as indicated by direction of the arrow on the element.

General

WARNING

Never attempt to disconnect RF equipment from the transmission line while RF power is being supplied. Leaking RF energy is a potential health hazard.

The Model 8745/46 Termaline Coaxial Load Resistors are rugged units of simple design, requiring only nominal and routine attention. The load is designed to operate for long periods of time if care is taken not to exceed its power handling capabilities.

Preventative Maintenance

Due to the basic simplicity of construction, the major requirement for preventive maintenance is to keep the equipment clean.

Inspection

With the rugged and simple construction of the loads, periodic inspection will only be necessary at six-month intervals. Inspection should include the items listed below:

- Cleanliness - Keep the housing and connector free of grime.
- Inspect the load for completeness and general condition of the equipment.
- A Troubleshooting Chart lists the commonly encountered problems, their possible causes and remedies. Use this chart as a guide when analyzing symptoms.

Cleaning

Outside Surface

The outside surface of these loads should be wiped free of dust and dirt when necessary. Periodically wipe the accumulated dust and lint off of the load housing.

RF Connector Surfaces

If the Teflon insulator or metallic contact surfaces of the connector should become dirty or grimy, wipe them off with a soft cloth. Use a contact cleaner that is self-drying and leaves no residue to clean the hard to reach internal portions.

Note: *Always handle the load with care to prevent subjecting it to unnecessary shock or impact.*

Optional Flow Switch

The Water Flow Switch, P/N 5-898-2, should be checked and cleaned of any accumulated dirt on scale that might impede free movement of the control gate in the switch. This should be done after several months use, or if otherwise indicated.

RF Assembly Resistance Test

Note: *These tests are by no means a necessity to the operation of the load but merely guidelines for the users information.*

Accurate measurement of the DC resistance between the inner and outer conductors of the RF input connector will provide a good check of the condition of the load resistor. Checking the DC resistance is simply used to measure a change in the condition of the resistor over time. The tracking of the DC resistance must start *before* the resistor is first put into service. Perform the following steps and record the value for future comparison. Check and record the resistance of the load periodically according to use.

Preparation:

- Tools: Common hand tools.
- Ohmmeter with an accuracy of $\pm 1\%$ at 50 ohms (or use a resistance bridge).
- Use low resistance leads, preferably a short piece of 50 ohm coaxial cable fitted with alligator clips.
- Temperature of the load between 20°C to 25°C (68°F to 77°F).

WARNING

Never attempt to connect or disconnect RF equipment from the transmission line while RF power is being applied. Leaking RF energy is a potential health hazard.

DC Resistance Measurement

Note: *It is recommended that this resistance check be performed each time the load is to be used.*

1. Turn off RF power and interlock circuitry before any electrical disconnections are made.
2. Disconnect the RF coaxial line.
3. Connect the multimeter test leads across the center and outer conductor of the load resistor. See [Figure 1](#).
4. Record the value of the resistance *before* the load is put into service. Compare subsequent values with the latest reading. If the values vary more than 2 ohms this could be an indication of a failing resistive element.

Figure 1 *Measuring DC Resistance*

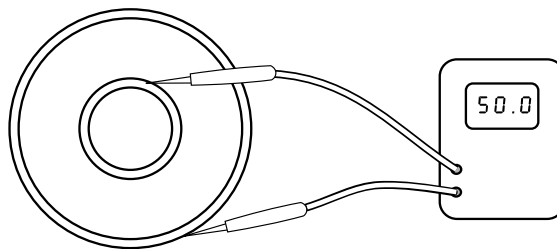

Troubleshooting

For corrections requiring repair or replacement of components, refer to the appropriate section for your specific model.

Problem	Possible Cause	Correction
Transmitter shuts off or will not stay on. Note: <i>This applies to units with flow interlock only.</i>	Low or no water flow	Increase cooling water flow.
	Faulty Flow Switch	Perform "Preoperational Checkout" on page 7. If switch fails to operate, replace switch, see "Replace the Water Flow Switch" on page 17
High load VSWR.	Failing resistor	Perform "RF Assembly Resistance Test" on page 11 . Resistance change of greater than 5 ohms indicates a failing resistor. Replace resistor, see "Replacing a Resistive Element" on page 12 .
	Loose input connector.	Tighten connector.

Repair

Replacing a Resistive Element

This series of water-cooled loads is designed to be quickly and easily repaired in the field. If in performing the [RF Assembly Resistance Test](#) described previously, a significant change in resistance is noted, or if for any reason the resistive element should fail, inexpensive replacement resistors are available. They can be installed in the load, using the following procedure:

Note: Item numbers enclosed in brackets "[]" in the text are so indicated in [Figure 2 on page 14](#) and [Figure 3 on page 16](#) and in ["Replacement Parts" on page 21](#).

Note: Turn off RF Power and interlock circuitry prior to proceeding.

1. Ensure the RF power and water supply are turned off.
2. Disconnect the water hoses at the hose fittings [5] on load. See [Figure 2 on page 14](#).
3. Disconnect the unit from the RF transmission line.
4. Completely drain excess water from the load.
5. Set the load on end, with the water connections up.

Note: Use a 3/16 inch hex Allen wrench.

6. Unscrew the six 1/4-20 x 2-1/2 inch socket head cap screws [6] holding the water chamber [3] to the main load housing.

Note: It may be necessary to rock the chamber gently while carefully pulling it off.

7. Pull the water chamber assembly (with screws) straight off.

The inner flow tube [9] will usually come out with the water chamber assembly, being held to it by the compression of the inner O-ring [4] (water input) seal. This is normal, and if the resistor body is unbroken, there will be no need to remove the inner flow tube from water chamber assembly.

The resistor cap assembly [11] is fitted tightly within the water chamber and should normally remain with it. If the inner flow tube has stayed in the resistor section, simply grasp the resistor sleeve [7] on the flow tube and pull out the assembly.

Note: This includes the cushioning O-Ring [8] which fits loosely below the resistor sleeve - always take care not to lose it by falling off. Also, if the brass resistor sleeve [7] is removed at all, notice that it has a small escape hole at the side and an access counterbore leading to it.

8. For reassembly, ensure the counterbore is facing toward the O-Ring and the resistor [1].

Note: This is essential for internal water venting. Notice the water output holes and also the small shoulder at the base of the inner flow tube. At reassembly, this must fit into a mating recess in the input fitting at the bottom.

9. Pull the resistor [1], if intact, straight out of the load housing.

Note: The outer flow tube is captive, and will not come out of the housing at this stage.

Inspecting the Unit

Note: Perform this once the resistor has been successfully removed.

Note: In the majority of cases, even in the event of resistor failure, the resistor substrate will remain intact.

1. Inspect the resistor carefully to ensure that it is not fractured.
2. Examine the inside of the load housing assembly for any apparent damage to the internal parts.
3. Do one of the following:
 - **If no damage had been found** - Proceed with new resistor replacement, [see "Installing the Resistor" on page 15.](#)
 - **If the resistor is broken, other internal parts appear to be damaged, or if they do not fit together properly** - See ["Replacing Fractured Resistors" on page 15.](#)

Figure 2 Resistor Removal

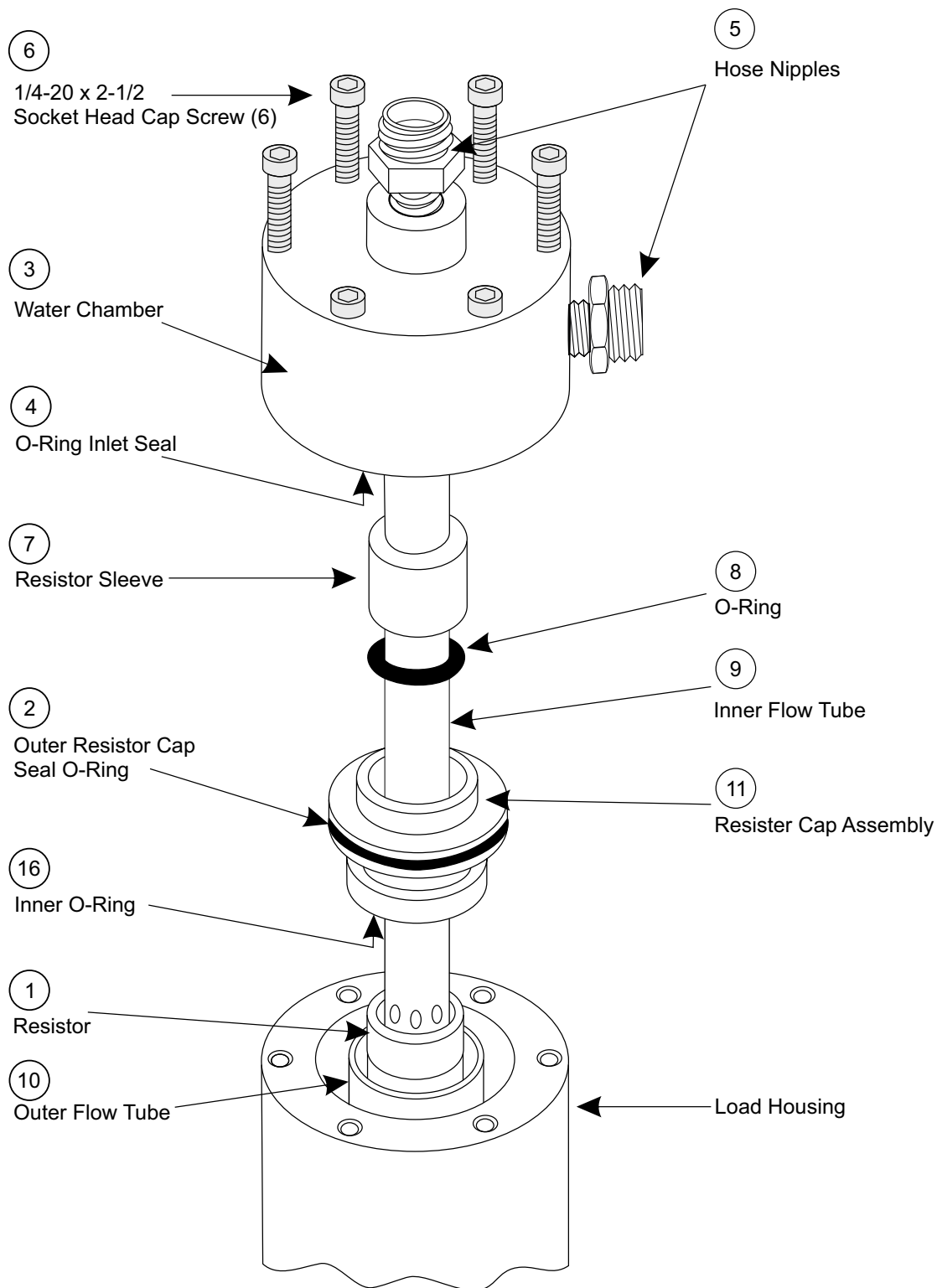

Installing the Resistor

1. Inspect the load housing assembly. See "[Inspecting the Unit](#)" on page 13.
2. Insert new resistor [1] into the load housing until it reaches its fitting.
3. Push in the resistor until it bottoms snugly.
Note: *The resistor should not have to be forced into the fitting, but it should be quite snug.*
4. If the resistor is loose in the fitting, press the slotted finger contacts of the fitting together slightly and try the resistor again. Continue closing the ends of the resistor fitting until a snug fit is obtained.
5. Place the inner flow tube [9] inside the resistor.
6. Lower the inner flow tube until it reaches the resistor fitting.
Note: *This operation may also be done if the inner flow tube is still in position in the water chamber.*
7. Gently work and twist the inner flow tube until it seats in the bottom of the input resistor fitting.
Note: *Watch the orientation of the sleeve, see [step 8](#) of "[Replacing a Resistive Element](#)" on page 12.*
8. Ensure that the O-Ring [8] cushion is placed on the inner flow tube next to the resistor and the "backup" resistor sleeve [7] is right behind it.
Note: *There is no need to disturb the resistor cap assembly [11] in the water chamber for this procedure.*
9. Replace the water chamber [3], gently rocking and twisting the chamber to achieve the proper flat seat on the outer housing.
Note: *If the water chamber [3] does not seem to fit properly, refer back to [step 7](#) to see that the inner flow tube is properly in place.*
10. Tighten the six 1/4-20 x 2-1/2 inch socket head cap screws [6].
Note: *Resistance should be approximately 50 ohms, see "[RF Assembly Resistance Test](#)" on page 11.*
11. Check the DC resistance between the inner and outer conductors.
12. Connect the load to a water source and check for leaks.
Note: *If there are NO leaks, the load is ready for service.*

Replacing Fractured Resistors

WARNING

The resistor used in this load consists of a resistive film on a special substrate. If the substrate is broken, there will probably be sharp pieces or splinters inside the load housing. Caution should be exercised to avoid possible injury.

- Note:** *The load should already be disassembled to the point of [step 7](#) of "[Replacing a Resistive Element](#)" on page 12.*
1. Turn the load on end with the RF connector up.
Note: *The RF input connector should be up to allow any loose pieces of resistor to fall out of the load housing.*
Note: *Use a 3/16 inch Allen wrench.*
 2. Loosen and remove the six 1/4-20 x 1 inch socket head cap screws [15] from the flanged end of the load housing. See [Figure 3 on page 16](#).
Note: *As shown in [Figure 3](#), the outer conductor assembly may now be easily removed.*
 3. Remove the input center conductor assembly [12] by pulling it out of the load housing ([Figure 3 on page 16](#)).
 4. Carefully remove any remaining pieces of the resistor.

Note: Normally, at this stage of the disassembly, the outer flow tube [10] will remain with the load housing. Restore it to this position after inspection and cleaning if it should come out.

5. Inspect the inside of the load housing for any apparent damage. See ["Inspecting the Unit" on page 13](#).
6. Pull out the inner flow tube [9]. See [Figure 2 on page 14](#).
7. Inspect the inner flow tube carefully for broken pieces.
8. Grasp the projecting hub of the resistor cap assembly [11] firmly.
9. Pull the projecting hub straight off with a strong even force.
10. Wash all the inside portions of the three assemblies (input section, load housing, and water chamber) thoroughly under clear running water.
11. Replace the resistor cap assembly in the water chamber.
12. Push the resistor cap assembly firmly onto the bottom.

Figure 3 RF Input Assembly

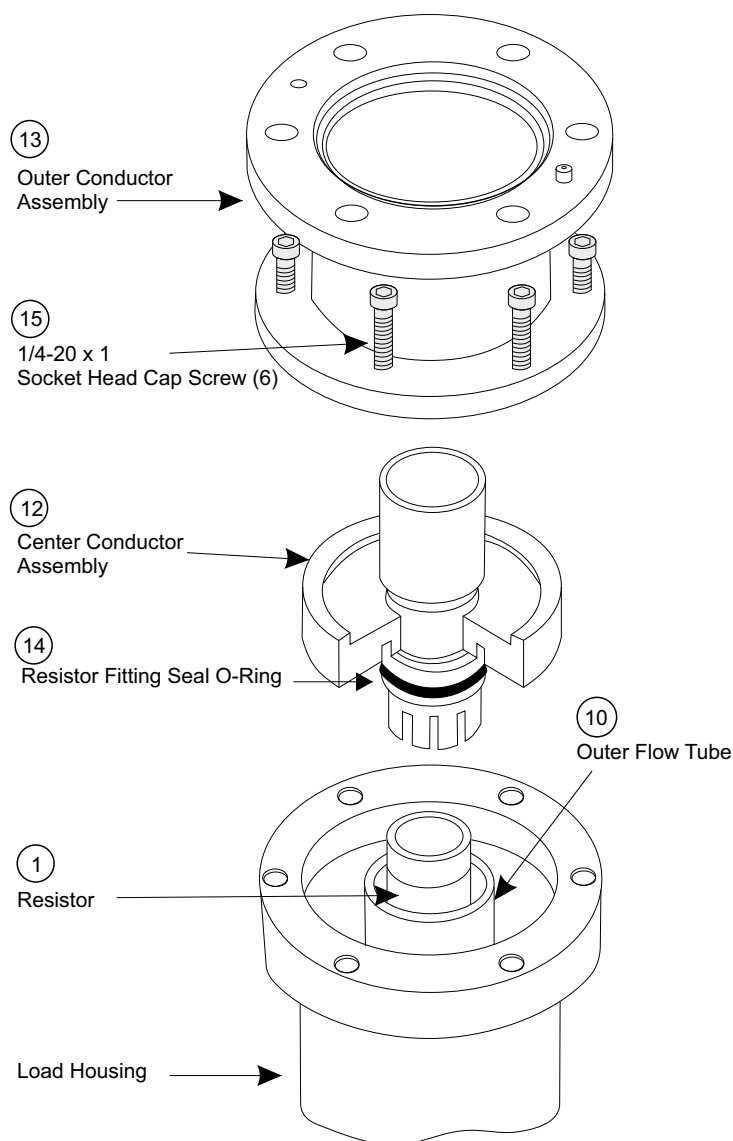

Installing a Replacement Resistor

1. Insert replacement resistor [1] into the resistor fitting of the input center conductor assembly to test its tightness.
2. Push in the resistor until it bottoms snugly.
Note: *The resistor should not have to be forced into the fitting, but it should be quite snug.*
3. If the resistor is loose in the fitting, press the slotted finger contacts of the fitting together slightly and try the resistor again. Continue closing the ends of the resistor fitting until a snug fit is obtained.
4. Bottom the resistor in the fitting.
5. Insert the resistor [1] and the input center conductor assembly [12] into the load housing with the resistor still in place in the resistor fitting ([Figure 2 on page 14](#)).
6. Replace the outer conductor assembly [13] and the six 1/4-20 x 1 inch socket head cap screws [15].
7. Stand the load on end with the RF input connector down.
8. Place the inner flow tube [9] inside the resistor.
9. Lower the inner flow tube until it reaches the resistor fitting.
10. Gently move and twist the inner flow tube until it seats in the bottom of the resistor fitting.
11. Continue using the procedure as given in "[Installing the Resistor](#)" on page 15.

Optional Equipment Repair

Replace the Water Flow Switch

The Water Flow Switch, P/N 5-898-2, should be checked and cleaned of any accumulated dirt or scale that might impede free movement of the control gate in the switch. This should be done after several months use, or if otherwise indicated. This component is non-repairable; if found defective it must be replaced. For replacement proceed as follows:

1. Ensure the following is shut off.
 - RF power
 - 115 VAC
 - Transmitter interlock supply
2. Disconnect the water flow switch leads at the control box.
3. Remove the defective switch.
4. Replace with new unit.
5. Connect the flow switch leads to terminals 3 and 5.
6. Perform preoperational checkout. See "[Preoperational Checkout](#)" on page 7.

Replace Time Delay Relay

Note: *The Relay Cartridge, P/N 5-1664, in the control box cannot be disassembled or repaired in the field. A faulty unit should simply be replaced according to the following procedure:*

1. Ensure the following is shut off.
 - RF power
 - 115 VAC
 - Transmitter interlock supply
2. Open the door of the control box by turning slotted screw head one quarter turn.
3. Loosen the 8-32 pan head screw at the top of the relay clamp, P/N 8630-193, then press legs in slightly to release the retaining prongs of the clamp.

4. Pull the delay relay cartridge straight out of the socket.
5. Position new relay above socket.
6. Rotate the cartridge carefully for alignment of the center post nub in the socket while inserting the relay.

Note: *The socket is an ordinary octal type.*

7. Position prongs of the relay clamp to match side slots in the socket holder.
8. Fit the clamp in the slots.
9. Turn the pan head screw until snug.
10. Close and secure the door of the control box by turning slotted screw head one quarter turn.
11. Perform preoperational checkout. See "[Preoperational Checkout](#)" on page 7.

Replace the Lamp

1. Locate the lamp (P/N 5-970-1) on the top of the control box.
2. Push down, gently, and twist the lamp lens (P/N 8750-106).
3. Remove the lamp lens.
4. Remove the lamp.
5. Install the new lamp by reversing this procedure.

Additional Repairs

Repairs beyond what is covered in this instruction book will require return of the equipment to Bird Electronic Corporation for service. See "[Customer Service](#)" on page 19.

Storage

Note: *If the load is to be unused or stored for any length of time, completely drain it of any coolant and cap the openings.*

1. Contain or cover the unit with plastic.
2. Store in a cool, dust free and dry area.

Note: *Ambient storage temperatures are not critical, however, extreme temperatures should be avoided.*

Shipping

1. Completely drain the unit of all coolant.
2. Cap all openings.
3. Pack the unit securely in a sturdy wooden box or equivalent.

Note: *If possible, use the original shipping carton for reshipment.*

4. Pad the container with sufficient padding to avoid shock damage.
5. Seal the container securely.

Customer Service

Any maintenance or service procedure beyond the scope of those in this chapter should be referred to a qualified service center.

If the unit needs to be returned for any reason, request an Return Material Authorization (RMA) through the Bird Technologies website. All instruments returned must be shipped prepaid and to the attention of the RMA number.

Bird Service Center

30303 Aurora Road
Cleveland (Solon), Ohio 44139-2794
Fax: (440) 248-5426
E-mail: bsc@birdrf.com

For the location of the Sales Office nearest you, visit our Web site at:

<http://www.birdrf.com>

Specifications

Power Rating	20,000 Watts
Impedance	50 ohms
Input Connectors Model 8745 Model 8746	3-1/8. EIA flanged (50 ohm) 3-1/8. unflanged (50 ohm) flush center conductor
Frequency Range	1000 Hz to 900 MHz
VSWR	1.10 max. 1 kHz to 900 MHz
Modes	CW, AM, FM, SSB, TV, and certain Pulse types
Input Water Temperature Range	5°C to 60°C (41°F to 140°F)
AC Power Required	115 V 50/60 Hz (with optional items only)
Water Flow - Minimum Rate	6 GPM (22.7 lpm) at 5°C (41°F) to 8 GPM (30.3 lpm) at 60°C (140°F)
Water Connections	3/4 inch Standard Hose Thread
Cooling Water	100% potable /distilled water or up to 50% dilution with pure technical grade ethylene glycol.
Weight Model 8745 Model 8746	15 lb 13 oz. (7.2k9) 15 lb 5 oz. (7.0 kg)
Dimensions Length Overall Housing Diameter Maximum Diameter (Input Flange)	19-1/2" (495 mm) 3-1/2" (89 mm) 5-3/16" (132 mm)
Finish	Black Powder Coat
Housing Material	Aluminum Alloy and Brass
Operating Position	Any

* Standards for potable water have been established by the U.S. Public Health Service at a maximum of 500 ppm of total dissolved solids (ppm - parts per million or 1 mg per liter). Hardness of water (content of calcium and magnesium salts) should be less than 75 ppm. If the quality of the available water supply is doubtful or the mineral content is questionable, use distilled water.

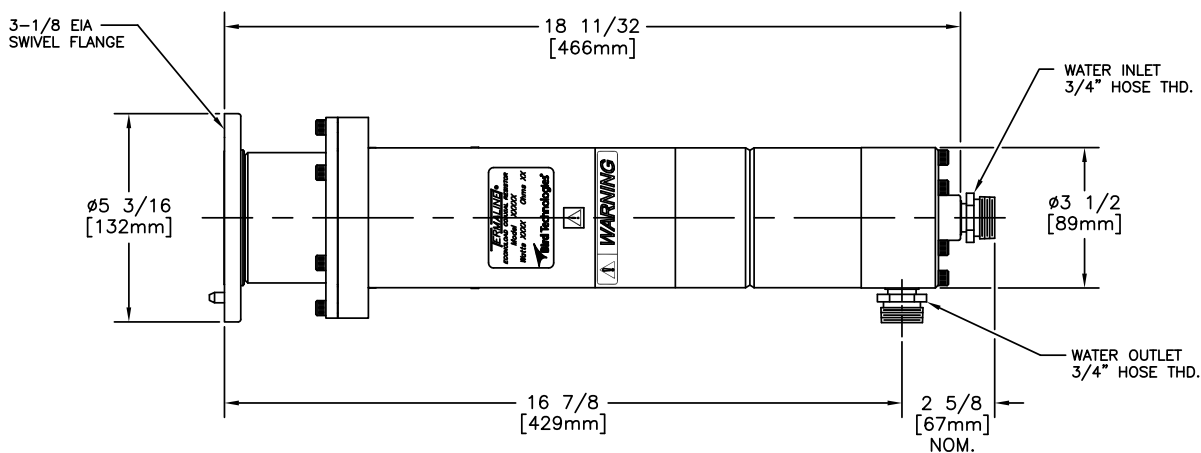

Replacement Parts

Figure	Item	Qty	Description	Replacement Kit	Part Number
2 and 3	1	1	Resistor	RPK8755-027-2	8755-027-2
2	2	1	Outer resistor cap seal, O-Ring	8740-020	8410-009
2	3	1	Water chamber		8755-014
2	4	1	Inlet seal O-Ring	8740-020	5-099
2	5	2	Hose nipple		5-065-2
2	6	6	Socket head cap screws, 1/4-20 x 2-1/2", stainless steel		1121-2508-00
2	7	1	Resistor sleeve	8740-025	8755-026
2	8	1	Sleeve backup O-Ring	8740-020	8110-059
2	9	1	Inner flow tube	8740-025	8755-025
2 and 3	10	1	Outer flow tube	8740-025	8755-024
2	11	1	Resistor cap assembly	8740-025	8755-005

RF Connector Parts Assigned Per Model Type:

Model 8745 - 3-1/8" EIA Connector 50 ohms

Figure	Item	Qty	Description	Part Number
3	12	1	Center conductor input, assembly	8755-007
3	13	1	Outer conductor assembly	8755-004

Model 8746 - 3-1/8" Unflanged Connector Flush Center Conductor 50 ohms

Figure	Item	Qty	Description	Part Number
3	12	1	Center conductor input, assembly	8756-003
3	13	1	Outer conductor assembly	8756-002

For Both Models

Figure	Item	Qty	Description	Part Number
3	14	1	Center conductor assembly O-Ring	5-1127
3	15	6	Socket head cap screws, 1/4-20 x 1," stainless steel	1121-1508-00
2	16	1	Inner resistor cap seal O-Ring	5-567

Optional Equipment

Qty	Description	Part Number
1	Water flow switch	5-898-2
1	Control assembly - 115 V	8750-101-1
1	Relay retaining clamp	8630-193
1	Time delay relay - 115 V*	5-1664
1	Indicator light*	8750-106
1	Incandescent lamp - 115 V*	5-970-1
1	Pipe nipple (flow switch)	5-489-1
	Hex bushing (flow switch)	5-490-1

* These items are part of the Control Assembly.

Accessory Coupling Kits

Fits Model	Description	Part Number
Model 8745	Coupling Kit - 3-1/8" EIA	4600-020
	consisting of:	
	Anchor Bullet	4600-021
	O-Ring	4600-022
	Mounting Hardware	4600-023
Model 8746	Coupling Kit - 3-1/8" Unflanged Flush - 50 ohm consisting of: Center Conductor Coupling Bullet Outer Conductor Sleeve Coupling Clamps-2	5-726

LIMITED WARRANTY

All products manufactured by Seller are warranted to be free from defects in material and workmanship for a period of one (1) year, unless otherwise specified, from date of shipment and to conform to applicable specifications, drawings, blueprints and/or samples. Seller's sole obligation under these warranties shall be to issue credit, repair or replace any item or part thereof which is proved to be other than as warranted; no allowance shall be made for any labor charges of Buyer for replacement of parts, adjustment or repairs, or any other work, unless such charges are authorized in advance by Seller.

If Seller's products are claimed to be defective in material or workmanship or not to conform to specifications, drawings, blueprints and/or samples, Seller shall, upon prompt notice thereof, either examine the products where they are located or issue shipping instructions for return to Seller (transportation charges prepaid by Buyer). In the event any of our products are proved to be other than as warranted, transportation costs (cheapest way) to and from Seller's plant, will be borne by Seller and reimbursement or credit will be made for amounts so expended by Buyer. Every such claim for breach of these warranties shall be deemed to be waived by Buyer unless made in writing within ten days from the date of discovery of the defect.

The above warranties shall not extend to any products or parts thereof which have been subjected to any misuse or neglect, damaged by accident, rendered defective by reason of improper installation or by the performance of repairs or alterations outside of our plant, and shall not apply to any goods or parts thereof furnished by Buyer or acquired from others at Buyer's request and/or to Buyer's specifications. Routine (regularly required) calibration is not covered under this limited warranty. In addition, Seller's warranties do not extend to the failure of tubes, transistors, fuses and batteries, or to other equipment and parts manufactured by others except to the extent of the original manufacturer's warranty to Seller.

The obligations under the foregoing warranties are limited to the precise terms thereof. These warranties provide exclusive remedies, expressly in lieu of all other remedies including claims for special or consequential damages. SELLER NEITHER MAKES NOR ASSUMES ANY OTHER WARRANTY WHATSOEVER, WHETHER EXPRESS, STATUTORY, OR IMPLIED, INCLUDING WARRANTIES OF MERCHANTABILITY AND FITNESS, AND NO PERSON IS AUTHORIZED TO ASSUME FOR SELLER ANY OBLIGATION OR LIABILITY NOT STRICTLY IN ACCORDANCE WITH THE FOREGOING.